

DOOR & DRAWER COMBO UPRIGHT REACH-INS

TOP MOUNT CONDENSING UNIT

Project Name: _____

Project Location: _____

Model #: _____ Quantity: _____

Available Warehouse: _____

ES Series

Model: ESWQ2D2



Refrigeration System

- Top mounted, self-contained and fully detachable Blizzard R290 condensing unit uses environmentally friendly, EPA-compliant R290 refrigerant with zero (0) Ozone Depletion Potential (ODP) and three (3) Global Warming Potential (GWP). Blizzard R290 is easily replaceable and requires no on-site brazing.
- Electronically commutated (ECM) fan motors achieve rapid cooling with less energy consumption.
- Full-length air duct system and airflow guard ensure optimal circulation of cold air.
- Time-initiated and temperature-terminated auto defrost cycle for seamless operation.
- Large capacity, corrosion-resistant condenser and evaporator coils.
- Self-maintaining, energy-efficient condensate drain pan requires no external drains or electric heaters.
- High performance, auto-reverse condenser fan motor supports compressor ventilation and condenser coil cleaning. Refer to owner's manual for full maintenance instructions.
- Pressure relief devices allow smooth access to cabinet interior when reopening doors.
- Pre-wired and ready to plug, 115V/60Hz/1Ph, NEMA 5-15P.

Cabinet Construction

- Heavy duty stainless steel interior / exterior with rounded corners for a hazard-free workspace.
- Insulated interior wall between refrigerator and freezer compartments.
- Galvanized steel top, bottom and rear.
- 2.5" thick high density polyurethane insulation.
- Four 5" swivel casters with locks on front set.

Lighting

- Energy efficient silicone coated and shatter-proof LED lighting provides bright, high color illumination with low heat output.

Doors

- Heavy duty stainless steel interior / exterior.
- 2.5" thick high density polyurethane insulation.
- Frame heaters prevent exterior moisture build up.
- Self-closing with adjustable torsion system for a positive seal.
- Thick gauge, stainless steel drawer frames with low-friction ball bearings.
- Snap-in magnetic door and drawer gaskets make cleaning and replacement an easy process.
- High strength, recessed door handles.
- Pre-installed door locks keep your items safe from theft (does not apply to drawers).

Shelving

- Epoxy coated, steel wire shelves (see table for quantity).
- Height adjustable stainless steel clips.

Temperature Control

- Multi-function digital controller with easy to read LED display.
- Factory preset temperature, 35°F for refrigerators and -4°F for freezers. Temperature setting range from 33°F to 54°F for refrigerators and -10°F to 54°F for freezers.
- Audible overheat protection alarm for compressor and condenser coil.

Options

- Additional shelving.
- 3" swivel casters with locks.
- 3.5" – 6" height-adjustable and interchangeable legs.



Please visit our website for updated Energy Efficiency information

Ref/ Frz/Dual	Doors	Capacity Cu. Ft.	Shelves	Refrigerant	HP	Power V-Hz-Ph	Amps	Crated Weight	Exterior Dimensions		
									L	D	H*
DUAL	1(FD) 1(H) 2(DR)	39(R) 13(F)	4	R-290	1/4+ (R) 1/3 (F)	115-60-1	5.5	556 lbs (252kg)	59" (1499mm)	31.625" (803mm)	74.25" (1886mm)

(†)Based on evaporating temperature of 23°F (-5°C) & condensing temperature of 131°F (55°C). (⌋) Product capacity is calculated based on standard industry figures. (✳) Reference plan view for clarification on caster/unit height. If dimensions and capacity are critical, please contact Everest Refrigeration. Blizzard R290 replacement is at the sole discretion of Everest Refrigeration. Specifications subject to change without notice.

DOOR & DRAWER COMBO UPRIGHT REACH-INS

TOP MOUNT CONDENSING UNIT

ES Series

Model: ESWQ2D2

DIMENSIONAL DATA

External Dimensions	L	59" (1499mm)
	D	31.625" (803mm)
	H*	74.25" (1886mm)
Crated Weight	556 lbs. (252kg)	
Doors/Drawers/Lids	1(FD) 1(H) 2(DR)	
Max Weight Support (LBS)	-	

STORAGE DATA

Net Capacity Cu. Ft. ▶	39(R) 13(F)
Shelves	4
Barrels	-
20 oz. Bottles	-
12 oz. Bottles	-
12 oz. Cans	-
8" Mugs	-
# of Pans (Top)	-
# of Pans (Drawer)	-
Dividers	-
Trays	-

ELECTRICAL DATA

Voltage	115-60-1
Full Load Amperage	5.5A
Feed Wires with Ground	3
Cord Length	9ft
NEMA Plug Type	 NEMA 5-15P

REFRIGERATION DATA

Compressor Mounting	Top
Refrigerant	R-290
Compressor HP	1/4+ (R) 1/3 (F)
BTU/HR †	1926(R) 2311(F)

KEY

D	Door	R	Refrigerator
L	Lid	REF	Refrigerator
H	Half Door	F	Freezer
FD	Full Door	FRZ	Freezer
SD	Solid Door	DUAL	REF/FRZ Combo
GD	Glass Door	DR	Drawer

	Elevation	Right	Plan	3D	Back

PLAN VIEW

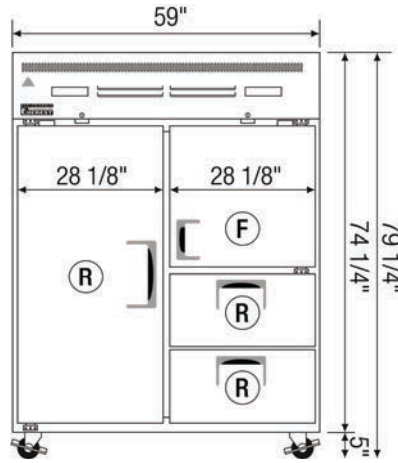

FRONT

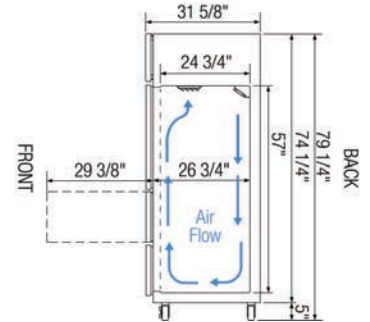

SIDE

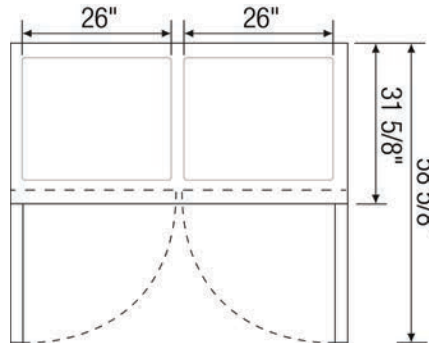

TOP

ACCESSORIES & OPTIONS

Part Number	Description
Additional Shelving	Contact Everest Refrigeration for more information.
AJL03-00	Interchangeable Leg for Caster (Optional)
CASA3-01	3" Overall Height Caster Assembly - (2) Front (2) Rear

(†)Based on evaporating temperature of 23°F (-5°C) & condensing temperature of 131°F (55°C). (▶) Product capacity is calculated based on standard industry figures. (✳) Reference plan view for clarification on caster/unit height. If dimensions and capacity are critical, please contact Everest Refrigeration. Blizzard R290 replacement is at the sole discretion of Everest Refrigeration. Specifications subject to change without notice.